

# Engine Driven High Pressure/Fire Pumps

Model 25FP13HR



Model 25FP23AR

- **Aluminum Construction with Replaceable Hard Coat Anodized Wear Ring**
- **Viton® Mechanical Seal with Silicon Carbide & Carbon Faces**
- **2-1/2" NPT Port Sizes**
- **Exhaust Prime or Hand Prime Depending on Model**
- **Prime Assist to 19 Ft.**
- **Built-in Discharge Check Valve**
- **Discharge Pressure Gauge Included**
- **Suction Strainer, Nipples and Heavy Duty Steel Roll Frame with Battery Tray Included**
- **Maximum Head up to 165 PSI/ 380' TDH**
- **Delivers to 270 GPM**
- **Available with B&S Vanguard, Honda Gasoline or Yanmar Diesel with 12 Volt DC Electric Start**
- **Optional NPT to Fire Hose Thread Available – See Accessories Page**
- **Optional Wheel Kit Available**

The IPT Engine Driven line of High Pressure/Fire pumps deliver excellent pressure and flow for use in many applications including: fire protection, emergency fire fighting, washdown and AG/Sprinkler. Portable units feature metal fuel tanks installed on engine or frame depending on model. 12 Volt DC electric start engines with recoil starter from Briggs & Stratton Vanguard, Honda Gasoline or Yanmar Diesel engines are standard on these pumps. Vanguard models feature built-in exhaust prime. Honda and Yanmar models feature a manual hand prime. These pumps are equipped with Viton® Silicon Carbide/Carbon seal and Viton® O-rings/gaskets.

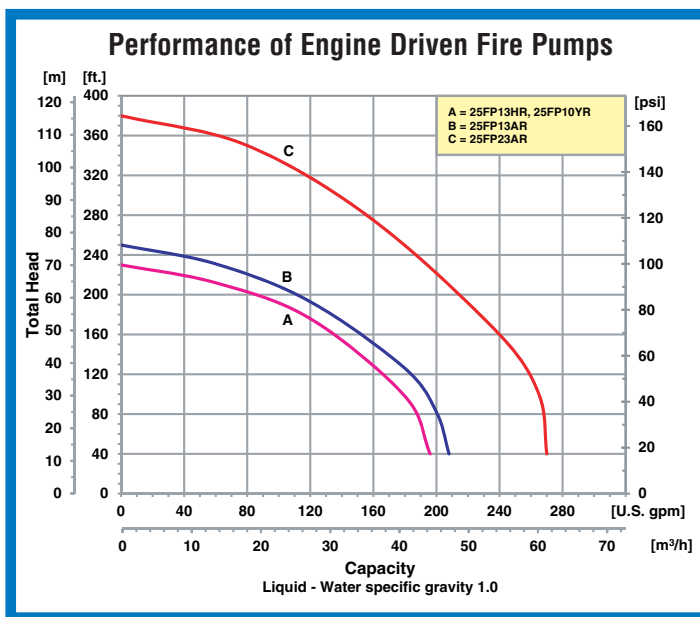

400 Spring Street • Royersford, PA 19468 USA

[www.amtpump.com](http://www.amtpump.com) • 888-amt-pump (268-7867)

For use with nonflammable liquids compatible with pump component materials. Viton® and Teflon® are registered trademarks of E. I. DuPont.



# Engine Driven High Pressure/Fire Pumps

## Pump Dimensional & Specification Data

Model	Curve	Driver	Seal Type & Elastomer/Faces	Prime Feature	Tank Size (Gal/Ltr)	Run Time (Hr.)	Ship Wt. (Lbs.)
25FP10YR	A	Yanmar L100 <sup>▲++</sup>	Viton <sup>®</sup> Silicon Carbide/Carbon	Hand	1.43 / 5.4	2.7	220
25FP13HR	A	Honda GX390 <sup>▲++</sup>	Viton <sup>®</sup> Silicon Carbide/Carbon	Hand	1.6 / 6.1	2.5	200
25FP13AR	B	B & S Vanguard 13 HP <sup>▲++</sup>	Viton <sup>®</sup> Silicon Carbide/Carbon	Exhaust	2.25/8.5	1.8	225
25FP23AR	C	B & S Vanguard 23 HP <sup>▲++</sup>	Viton <sup>®</sup> Silicon Carbide/Carbon	Exhaust	10/37.8	7.0	255

**Construction: Aluminum**

▲ Oil Alert Included

++ Electric Start

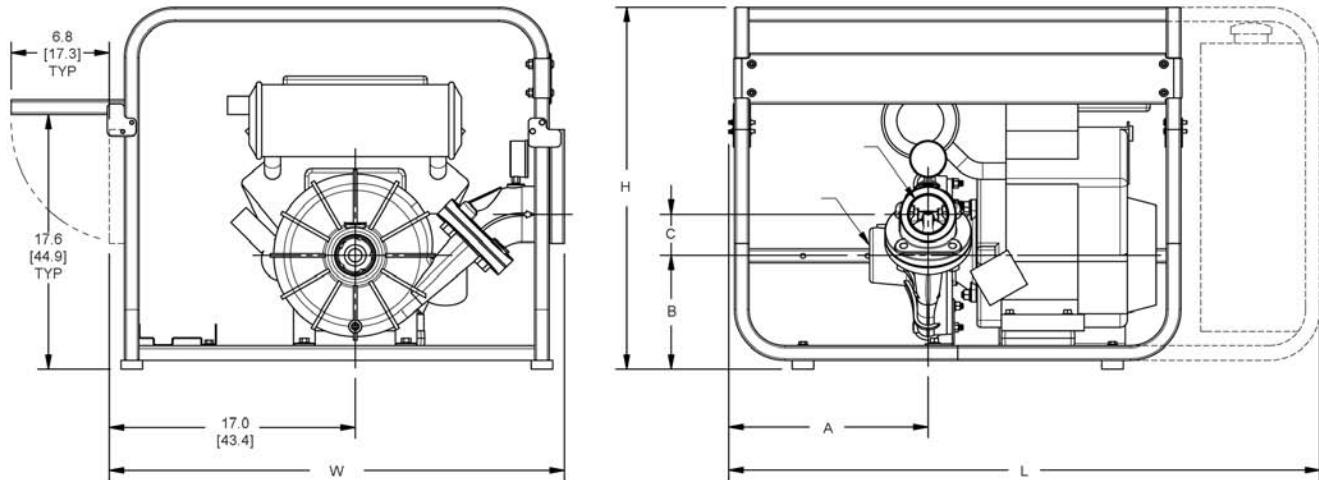

**Hand Primer Not Shown for Model 25FP13HR**

Model	HP Class <sup>◆</sup>	SUC*	DIS*	A	B	C	L**	W	H
25FP10YR	10 HP	2-1/2	2-1/2	13.3 [33.7]	8.1 [20.6]	4.6 [11.7]	31.8 [80.8]	31.6 [80.3]	25.1 [63.8]
25FP13HR	13 HP	2-1/2	2-1/2	13.3 [33.7]	6.8 [17.4]	4.6 [11.7]	31.8 [80.8]	31.6 [80.3]	25.1 [63.8]
25FP13AR	13 HP	2-1/2	2-1/2	13.3 [33.7]	6.8 [17.4]	4.6 [11.7]	31.8 [80.8]	31.6 [80.3]	25.1 [63.8]
25FP23AR <sup>†</sup>	23 HP	2-1/2	2-1/2	13.8 [35.2]	7.9 [20.1]	2.8 [7.2]	41.0 [104.3]	31.6 [80.3]	25.1 [63.8]

◆ HP Class represents market category and is not intended to define actual horsepower.

(\*) Standard NPT (Male) pipe thread.

(\*\*) This dimension may vary due to engine manufacturer's specifications.

NOTE: Dimensions are in inches (centimeters) and have a tolerance of  $\pm 1/8"$ .

(†) Minimal Assembly Required: Auxiliary Fuel Tank Shipped Uninstalled

## Standard Features

- Aluminum Construction with Replaceable Hard Coat Anodized Wear Ring
- Viton<sup>®</sup> Mechanical Seal with Silicon Carbide & Carbon Faces
- 2-1/2" NPT Suction & Discharge Ports
- Exhaust Prime or Hand Prime Depending on Model
- Built-in Discharge Check Valve
- Discharge Pressure Gauge Included
- Choice of Briggs & Stratton Vanguard, Honda Gasoline or Yanmar Diesel Engines with 12 Volt DC Electric Start
- Maximum Temperature 200° F
- Optional NPT to Fire Hose Thread Available – See Accessories Page
- Heavy Duty Steel Roll Frame with Battery Tray Included
- Optional High Pressure Hose Kit or Wheel Kit Available



**Manufacturer of AMT & IPT Pumps**

400 Spring Street • Royersford, PA 19468 USA

[www.amtpump.com](http://www.amtpump.com) • 888-amt-pump (268-7867)

The Gorman-Rupp Company reserves the right to discontinue any model or change specifications at any time without incurring any obligation.  
©2012 American Machine and Tool Company. All rights reserved.



1212